

Dokumentation

***Kugelhähne 2-teilig, mit vollem Durchgang,
bis 50 bar
- Typ KH ..., KH ... KN -***

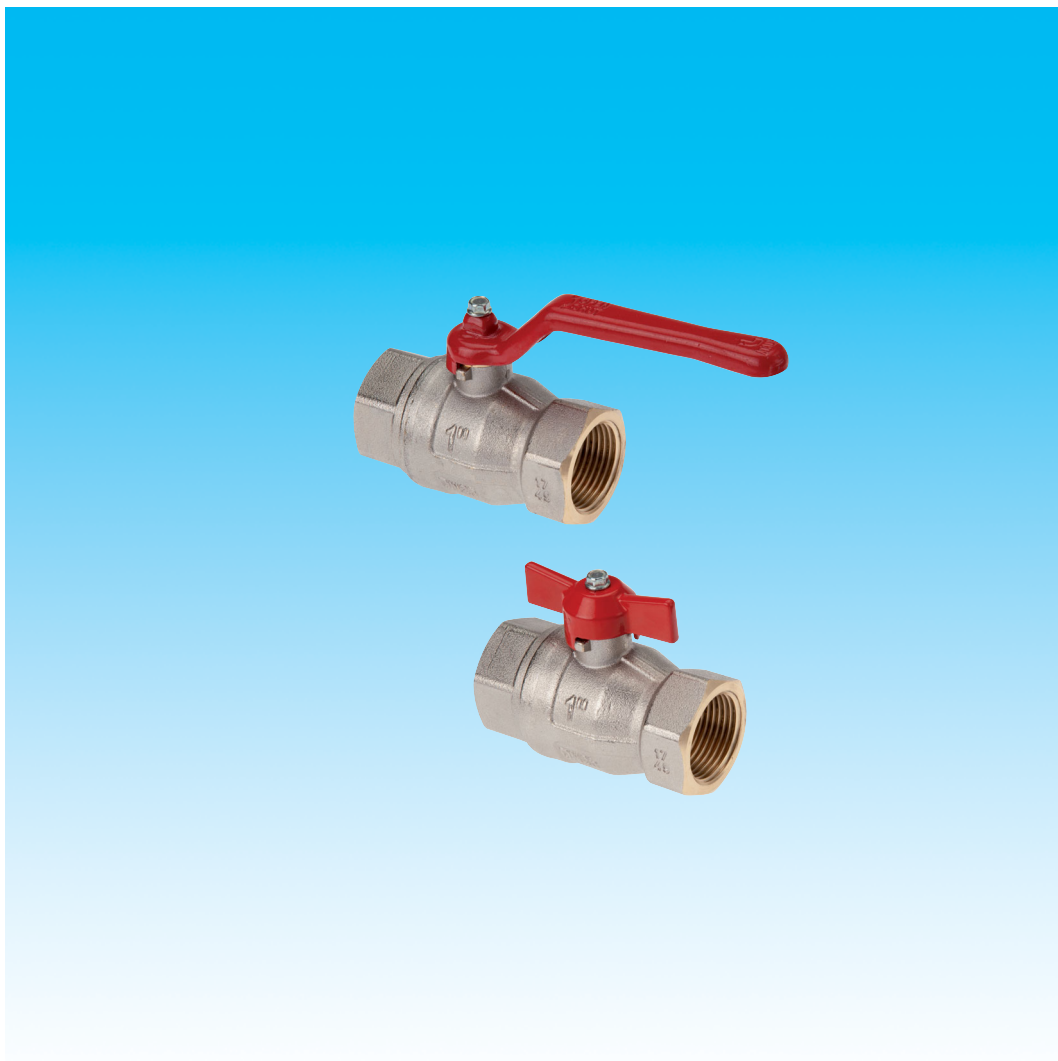

1. Inhalt

1. Inhaltsverzeichnis	1
2. Artikelnummern und technische Daten	1
3. Abmessungen	1
4. Installation	2
5. Druck-Temperatur-Diagramm	2
6. Druckverlust-Diagramm	3

2. Artikelnummern und technische Daten

Kugelhähne 2-teilig, voller Durchgang

bis 50 bar

Werkstoffe: Körper: Messing vernickelt, Kugel: Messing hartverchromt, Dichtung: PTFE/NBR

Temperaturbereich: -20°C bis max. +150°C

Medien: Wasser (kein Dampf), neutrale, gasförmige und nicht aggressive, flüssige Medien, Mineralöle, Druckluft,

Vakuum (max. -0,9 bar)

- Vorteile:**
- Baulänge nach DIN 3202-M3
 - Durch Zukauf optionaler Kombigriffe (Seite 497) können Sie viele verschiedene Handgriffvarianten realisieren:
 - Standardgriff in rot, gelb, blau und schwarz
 - Knebelgriff in den Farben rot, gelb, blau, schwarz und grün
 - Flachstahlgriff in rot, gelb und grün (optional: abschließbar***)
 - langer Griff in rot

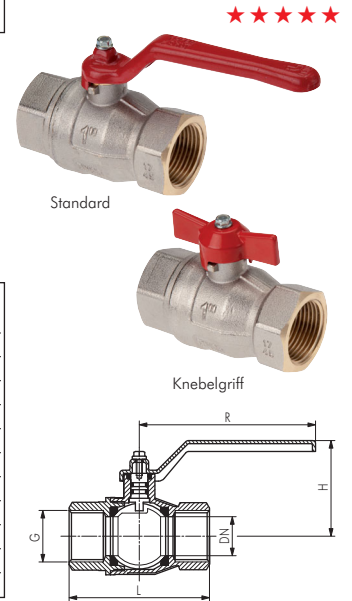

Typ	H	R	Typ	H	R	G	DN	L	PN	Kombigriff-Größe**
Standard			Knebelgriff							
KH 14	37	80	KH 14 KN	37	24	Rp 1/4"	10	49,5*	50 bar	1
KH 38	37	80	KH 38 KN	37	24	Rp 3/8"	10	52,4*	50 bar	1
KH 12	49	89	KH 12 KN	44	27	Rp 1/2"	15	75,0	50 bar	2
KH 34	58	113	KH 34 KN	50	31	Rp 3/4"	20	80,0	40 bar	3
KH 10	61	113	KH 10 KN	53	31	Rp 1"	25	90,0	40 bar	3
KH 114	75	138	---	---	---	Rp 1 1/4"	32	110,0	30 bar	4
KH 112	91	158	---	---	---	Rp 1 1/2"	40	120,0	30 bar	5
KH 20	98	158	---	---	---	Rp 2"	50	140,0	25 bar	5
KH 212	127	250	---	---	---	G 2 1/2"	65	148,0*	18 bar	7
KH 30	136	250	---	---	---	G 3"	80	168,0*	16 bar	7
KH 40	154	250	---	---	---	G 4"	100	204,0*	14 bar	7

* keine DIN-Länge, ** Kombigriffe finden Sie auf Seite 497, *** nicht für Kombigriff-Größe 3

3. Abmessungen

Hauptabmessungen - Kugelhähne 2-teilig, voller Durchgang

bis 50 bar

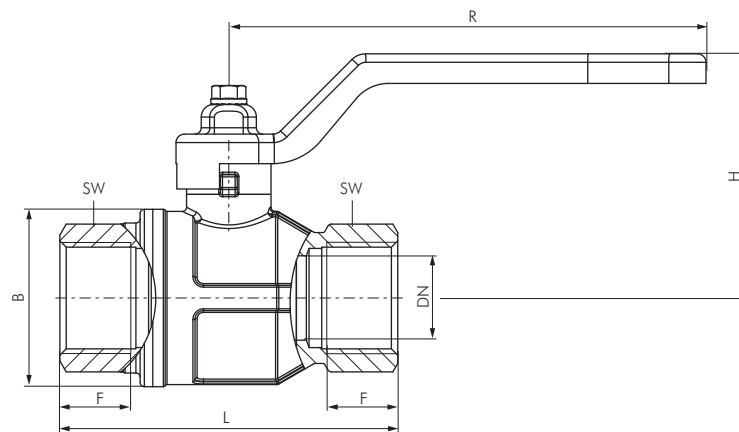

Typ	G	H	R	DN	L	F	B	SW
KH 14	Rp 1/4"	37	80	10	49,5*	11,0	23,5	18,0
KH 38	Rp 3/8"	37	80	10	52,4*	11,4	24,0	21,0
KH 12	Rp 1/2"	49	89	15	75,0	15,0	32,5	25,0
KH 34	Rp 3/4"	58	113	20	80,0	16,3	42,0	31,0
KH 10	Rp 1"	61	113	25	90,0	19,1	49,5	40,0
KH 114	Rp 1 1/4"	75	138	32	110,0	21,4	59,5	49,0
KH 112	Rp 1 1/2"	91	158	40	120,0	21,4	72,0	54,0
KH 20	Rp 2"	98	158	50	140,0	25,7	86,0	68,5
KH 212	G 2 1/2"	127	250	65	148,0*	25,0	122,0	85,0
KH 30	G 3"	136	250	80	168,0*	27,5	142,0	99,0
KH 40	G 4"	154	250	100	204,0*	30,0	180,0	125,0

* keine DIN-Länge

Alle Angaben verstehen sich als unverbindliche Richtwerte! Für nicht schriftlich bestätigte Datenauswahl übernehmen wir keine Haftung. Druckangaben beziehen sich, soweit nicht anders angegeben, auf Flüssigkeiten der Gruppe II bei +20°C.

Hauptabmessungen - Kugelhähne 2-teilig, voller Durchgang

bis 50 bar

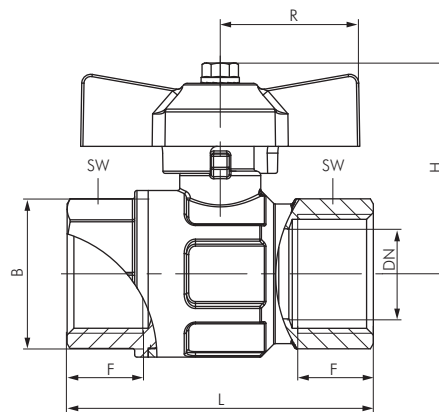

Typ	G	H	R	DN	L	F	B	SW
KH 14 KN	Rp 1/4"	37	24	10	49,5*	11,0	23,5	18
KH 38 KN	Rp 3/8"	37	24	10	52,4*	11,4	24,0	21
KH 12 KN	Rp 1/2"	44	27	15	75,0	15,0	32,5	25
KH 34 KN	Rp 3/4"	50	31	20	80,0	16,3	42,0	31
KH 10 KN	Rp 1"	53	31	25	90,0	19,1	49,5	40

* keine DIN-Länge

4. Installation

Die Ventile sind bidirektional, d.h. sie lassen den Durchfluss in beide Richtungen zu.

Die Ventile bestehen aus einer Kugel, zwei Dichtungen, einer Spindel, O-Ring, Griff und zwei Messingteilen, Ventilgehäuse und Muffe. Die Sicherheit der Gewindeverbindung wird durch eine spezielle Gewindesicherung gewährleistet.

Damit die Gewindesicherung nicht beschädigt und die Verbindung zwischen Ventilgehäuse und Muffe nicht undicht wird, dürfen die beiden Teile keinen Torsionsmomenten ausgesetzt werden.

Bei der Installation sind die üblichen Arbeitsweisen zu beachten, im Besonderen:

- prüfen, ob die beiden Rohrleitungen korrekt ausgerichtet sind
- beim Einbau den Schlüssel am Ventilende nahe am Rohr ansetzen
- die Anwendung von Dichtmaterialien (PTFE, Hanf) muss auf das Rohrgewinde beschränkt sein, ein Übermaß könnte in den Verschlussbereich Kugeldichtung eingreifen und die Dichtheit beeinträchtigen
- im Fluid enthaltene Verunreinigungen (Schmutz, Staub, sehr hohe Wasserhärte) müssen beseitigt oder gefiltert werden, um eine Beschädigung der Dichtungen durch die Kugeldrehung zu vermeiden

Ausbau

Beim Ausbau des Ventils aus der Leitung bzw. vor dem Abschrauben von Verbindungen:

- Schutzkleidung tragen, die üblicherweise bei Arbeiten mit dem in der Rohrleitung enthaltenen Fluid erforderlich ist
- gehen Sie wie folgt vor, um die Rohrleitung drucklos zu machen:
- das Ventil in die offene Stellung bringen und die Rohrleitung leeren
- das Ventil vor dem Ausbau aus der Rohrleitung mehrmals betätigen, damit der Restdruck aus dem Gehäusehohlraum entweichen kann
- beim Ausbau den Schlüssel am Ventilende nahe am Rohr ansetzen

Wartung

Das Ventil abhängig von seiner Nutzung und den Arbeitsbedingungen regelmäßig auf seinen korrekten Betrieb überprüfen.

5. Druck-Temperatur-Diagramm

Die Kennlinien stellen die maximale Einsatzgrenze der Ventile dar. Bei den Wertangaben handelt es sich um Richtwerte.

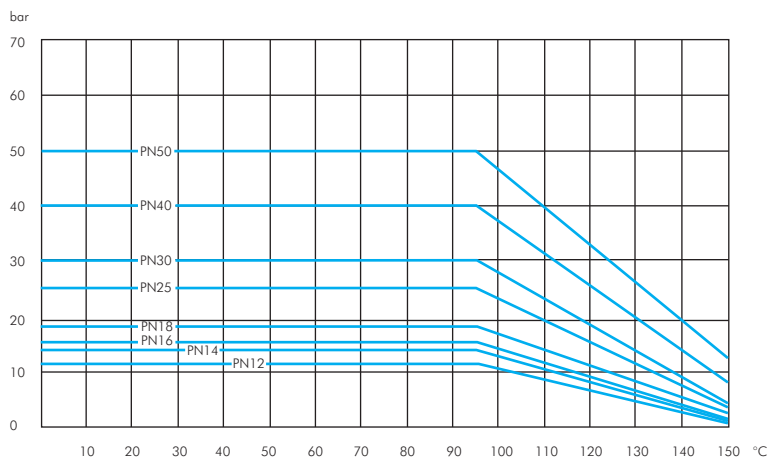

6. Druckverlust-Diagramm (mit Wasser)

1/4" bis 2"

	1/4"	3/8"	1/2"	3/4"	1"	1 1/4"	1 1/2"	2"	2 1/2"	3"	4"
KV	3,45	5,00	12,98	23,92	38,57	56,81	85	159	376	472	892

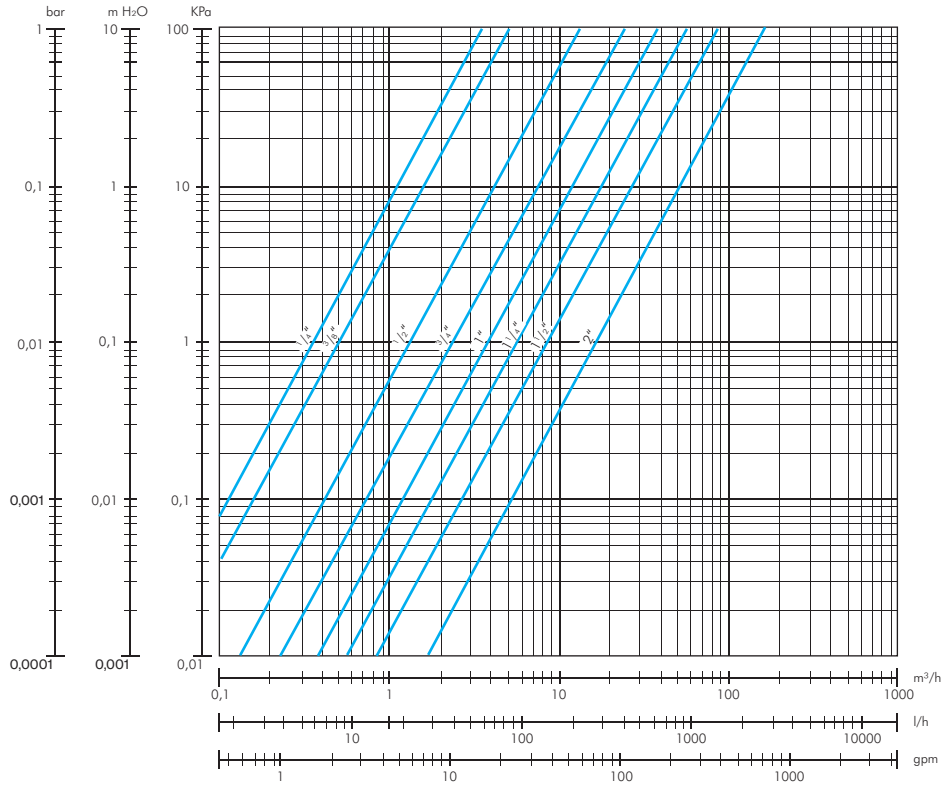

2 1/2" bis 4"

	1/4"	3/8"	1/2"	3/4"	1"	1 1/4"	1 1/2"	2"	2 1/2"	3"	4"
KV	3,45	5,00	12,98	23,92	38,57	56,81	85	159	376	472	892

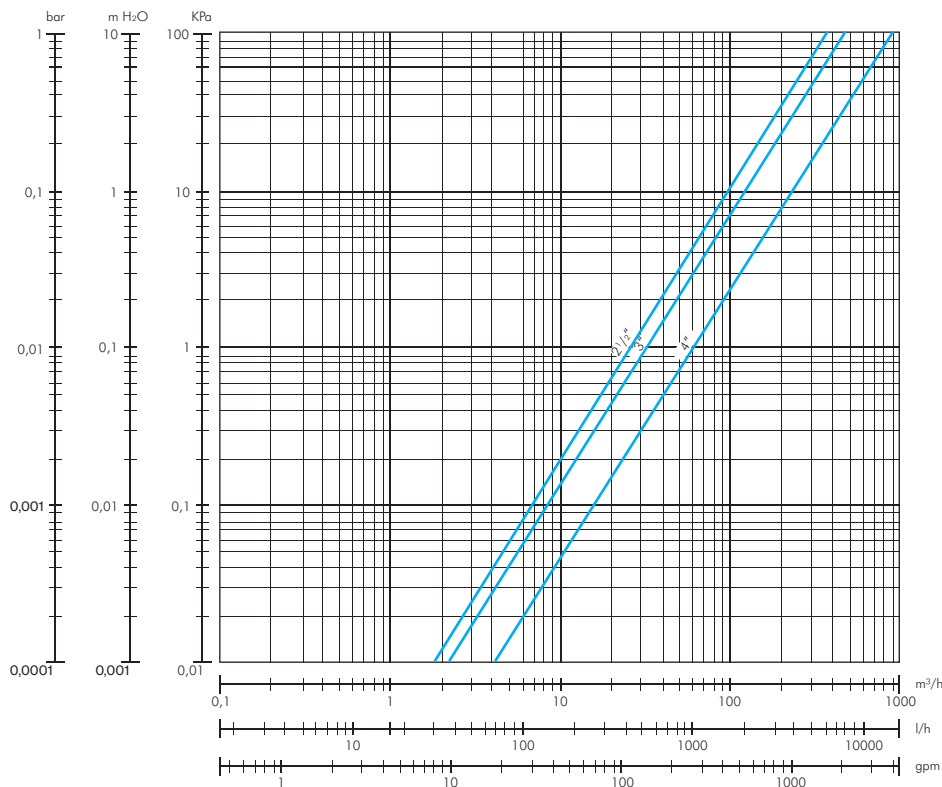

Documentation

***Ball valves 2-piece, full throughway
up to 50 bar
- Type KH ..., KH ... KN -***

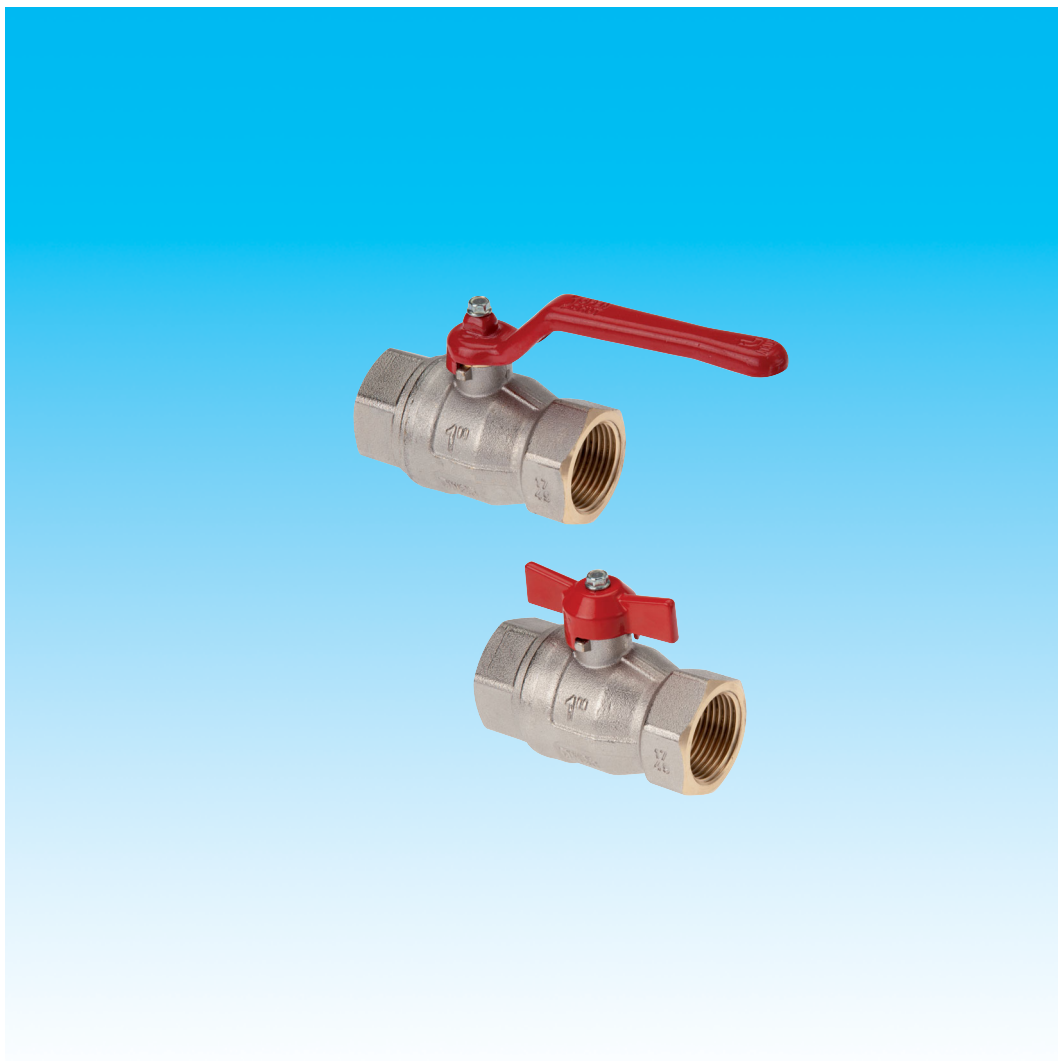

1. Content

1. Content	1
2. Articlenumbers and technical data	1
3. Dimensions	1
4. Installation	2
5. Pressure-temperature diagram	2
6. Pressure drop diagram	3

2. Articlenumbers and technical data

Ball valves 2-piece, full throughway

up to 50 bar

Materials: Housing: nickel-plated brass, ball: hard chromium plated brass, seal: PTFE / NBR

Temperature range: -20°C up to +150°C

Media: Water (no steam), neutral, gaseous and non-aggressive, liquid media, mineral oils, compressed air, vacuum (max. -0.9 bar)

Advantages: • Length according to DIN 3202-M3

- By purchasing the optional combi handles, you can construct various handle variations:
 - Standard handle in red, yellow, blue and black
 - Butterfly handle in red, yellow, blue, black and green
 - Flat-steel handle in red, yellow and green (optional: lockable**)
 - long handle in red

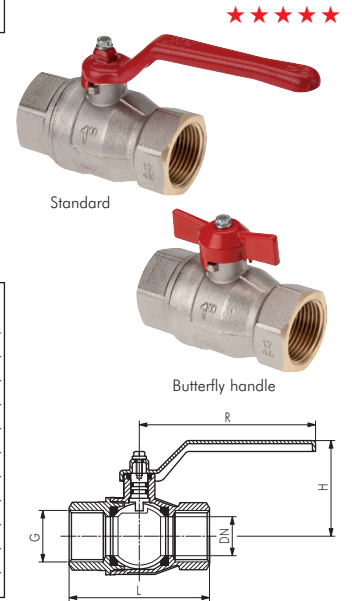

Type	H	R	Type	H	R	G	DN	L	PN	Handles-size**
Standard			Butterfly handle							
KH 14	37	80	KH 14 KN	37	24	Rp 1/4"	10	49,5*	50 bar	1
KH 38	37	80	KH 38 KN	37	24	Rp 3/8"	10	52,4*	50 bar	1
KH 12	49	89	KH 12 KN	44	27	Rp 1/2"	15	75,0	50 bar	2
KH 34	58	113	KH 34 KN	50	31	Rp 3/4"	20	80,0	40 bar	3
KH 10	61	113	KH 10 KN	53	31	Rp 1"	25	90,0	40 bar	3
KH 114	75	138	---	---	---	Rp 1 1/4"	32	110,0	30 bar	4
KH 112	91	158	---	---	---	Rp 1 1/2"	40	120,0	30 bar	5
KH 20	98	158	---	---	---	Rp 2"	50	140,0	25 bar	5
KH 212	127	250	---	---	---	G 2 1/2"	65	148,0*	18 bar	7
KH 30	136	250	---	---	---	G 3"	80	168,0*	16 bar	7
KH 40	154	250	---	---	---	G 4"	100	204,0*	14 bar	7

* No DIN length, ** Combihandles can be found on page 497, *** not for combi handle size 3

3. Dimensions

Main Dimensions - Ball valves 2-piece, full throughway

up to 50

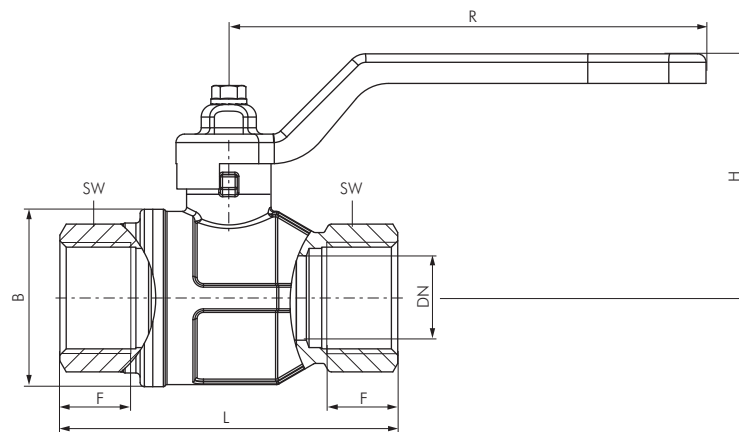

Type	G	H	R	DN	L	F	B	SW
KH 14	Rp 1/4"	37	80	10	49,5*	11,0	23,5	18,0
KH 38	Rp 3/8"	37	80	10	52,4*	11,4	24,0	21,0
KH 12	Rp 1/2"	49	89	15	75,0	15,0	32,5	25,0
KH 34	Rp 3/4"	58	113	20	80,0	16,3	42,0	31,0
KH 10	Rp 1"	61	113	25	90,0	19,1	49,5	40,0
KH 114	Rp 1 1/4"	75	138	32	110,0	21,4	59,5	49,0
KH 112	Rp 1 1/2"	91	158	40	120,0	21,4	72,0	54,0
KH 20	Rp 2"	98	158	50	140,0	25,7	86,0	68,5
KH 212	G 2 1/2"	127	250	65	148,0*	25,0	122,0	85,0
KH 30	G 3"	136	250	80	168,0*	27,5	142,0	99,0
KH 40	G 4"	154	250	100	204,0*	30,0	180,0	125,0

* No DIN length

All data are considered to be unbinding reference values. We accept no liability for data selection that is not confirmed in writing. Pressure data refer, if not otherwise indicated, to liquids of Group II at +20°C.

Main Dimensions - Ball valves 2-piece, full throughway

up to 50

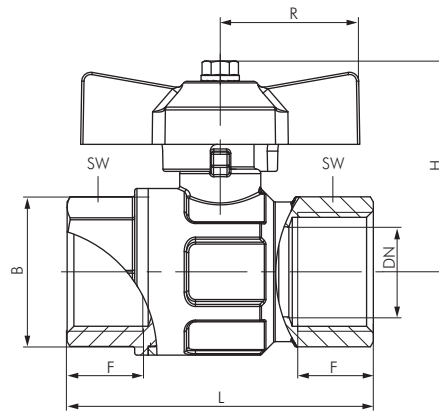

Type	G	H	R	DN	L	F	B	SW
KH 14 KN	Rp 1/4"	37	24	10	49,5*	11,0	23,5	18
KH 38 KN	Rp 3/8"	37	24	10	52,4*	11,4	24,0	21
KH 12 KN	Rp 1/2"	44	27	15	75,0	15,0	32,5	25
KH 34 KN	Rp 3/4"	50	31	20	80,0	16,3	42,0	31
KH 10 KN	Rp 1"	53	31	25	90,0	19,1	49,5	40

* No DIN length

4. Installation

The valves are bi-directional, that means they manage the flow in both the directions.

The valves are composed by a ball, two seal in PTFE material, one stem, two sailing rings (O-Rings), one handle and a couple of parts made of brass (body and end adapter) that contain them and that are assembled by means of thread and a sealed material to obtain their aim.

In order to avoid that the sealed material gets broken and then the valve loses the connection between the body and the endadapter, it's necessary to avoid to submit the two parts under the influence of a torque.

For the installation normal hydraulic practices must be used, and especially:

- ones have to be sure that the two pipes are correctly aligned;
- during the assembling process the installer has to apply its assembling tools at the end that is nearest to the pipe;
- the application of the sealing materials by the fitter (PTFE or hempen cloth) must be limited at the thread zone. An excess should interferes in the ball-gasket's closure zone, compromising the tightness.
- in the case that the fluid transported presents some impurities (dust, water too hard, etc.) ones have to remove these impurities by the means of a filter. Otherwise they could damage the seals.

DISASSEMBLY

To remove the valve from the pipe line or anyhow before to unscrew the junctions linked to it:

- wear the clothing protective normally required to work with the fluid transported within the line;
- depressurize the line and operate in this way:
- positioning the valve in opened position and than empty the line;
- handle the valve to put down the residue pressure contained inside the space between the ball and the body before of remove it from the line;
- during the disassembly apply the screw tool at the end of the valve nearest the pipe;

MAINTENANCE

Verify the valve periodically, according to its application's field and its works' field and its work's conditions, in order to be sure that the valve works correctly.

5. Pressure drop diagram

The values shown by the dropping lines state the maximum limit of employment of the valves. The shown values are approximate.

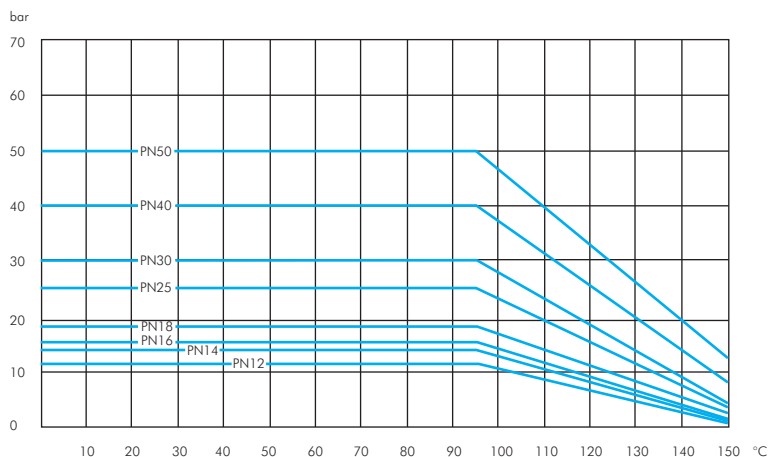

All data are considered to be unbinding reference values. We accept no liability for data selection that is not confirmed in writing. Pressure data refer, if not otherwise indicated, to liquids of Group II at +20°C.

6. Pressure drop diagram (with water)

1/4" up to 2"

	1/4"	3/8"	1/2"	3/4"	1"	1 1/4"	1 1/2"	2"	2 1/2"	3"	4"
KV	3,45	5,00	12,98	23,92	38,57	56,81	85	159	376	472	892

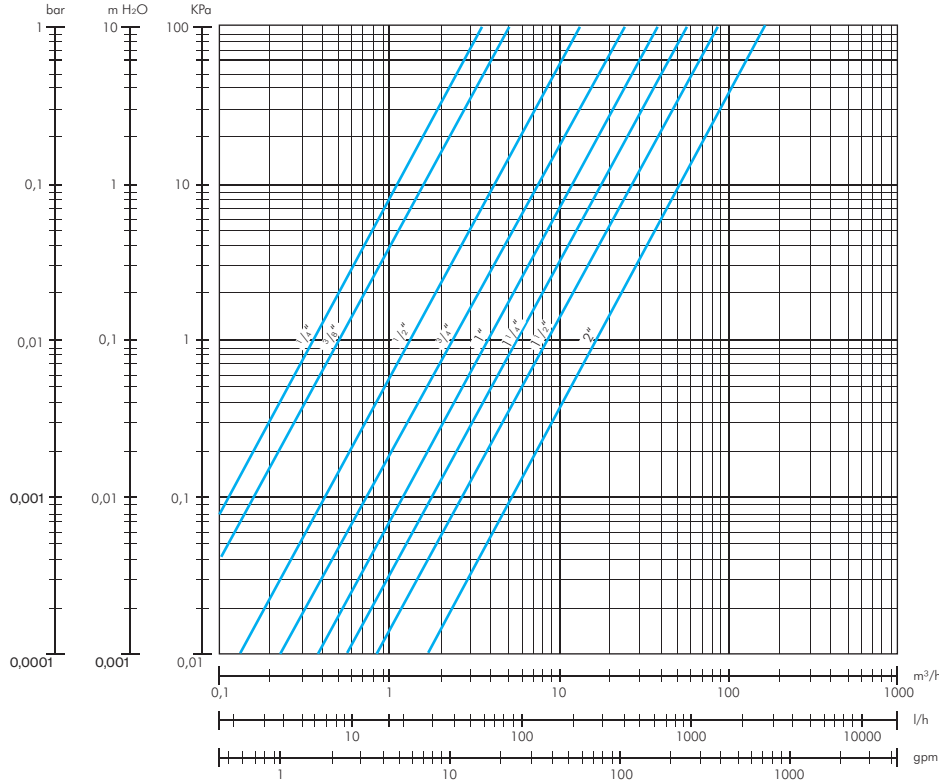

2 1/2" up to 4"

	1/4"	3/8"	1/2"	3/4"	1"	1 1/4"	1 1/2"	2"	2 1/2"	3"	4"
KV	3,45	5,00	12,98	23,92	38,57	56,81	85	159	376	472	892

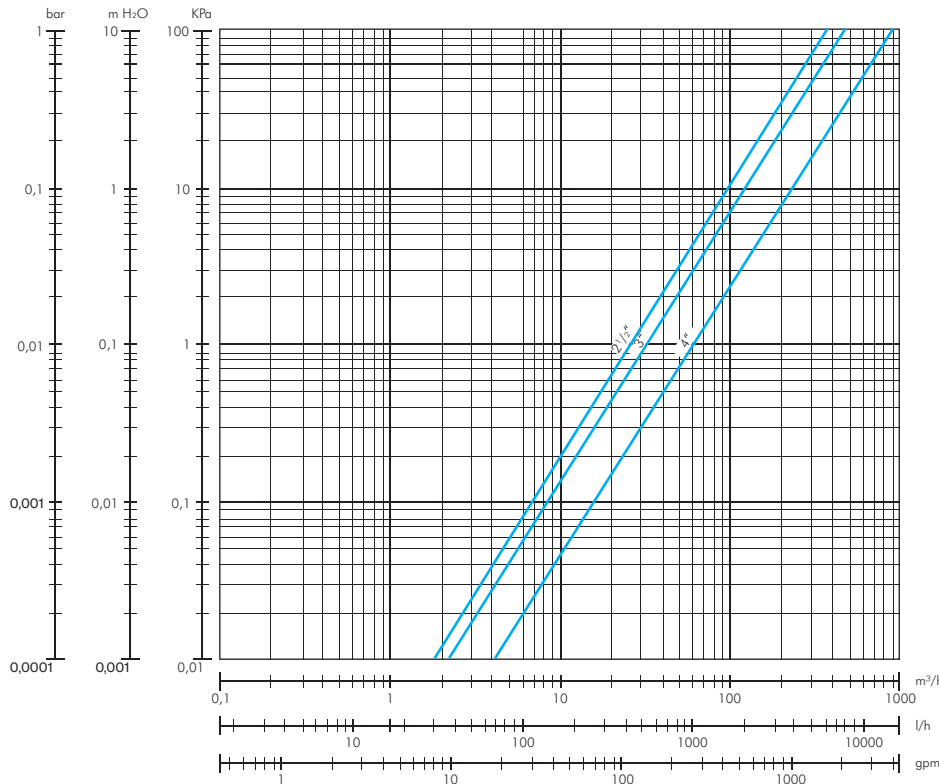

All data are considered to be unbinding reference values. We accept no liability for data selection that is not confirmed in writing. Pressure data refer, if not otherwise indicated, to liquids of Group II at +20°C.